

INDUSTRIAL TURBINE VENTILATORS

Assembly and Installation Procedures

VENTILATOR COMPONENTS

The standard Alsynite Ventilator consists of these components: Turbine, Variable Pitch Tube and Base Flashing. Set out below are stepwise installation instructions.

The Alsynite Industrial Ventilator is designed so that it will not allow water ingress in normal weather conditions. Quality installation work is critical, care should be taken to eliminate the risk of leaks through the flashing or fasteners.

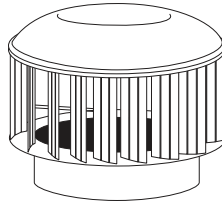

Turbine Head

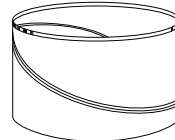

Variable Pitch Tube

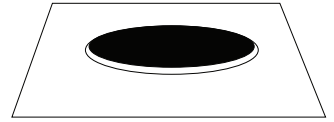

Base Flashing

STEPWISE INSTALLATION INSTRUCTIONS

Step 1

Select the appropriate position on the roof.

Note: when selecting the position of the vent, the means of weatherproofing needs to be taken into account, the most efficient means is to locate the flashing under the ridge cap.

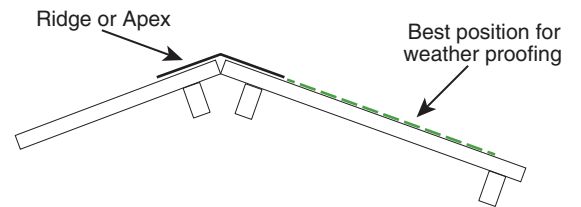

Step 2

Place the base flashing under the ridge capping. Ensure that the base flashing covers the corrugations or ribs equally, then mark a circle using the base as a template. Cut hole. Once the hole has been cut, turn up the corrugations or pans and secure the flashing to the roof.

It is recommended that an infill be used on the low side of the flashing.

Coat fasteners with silicone to ensure they're weatherproof.

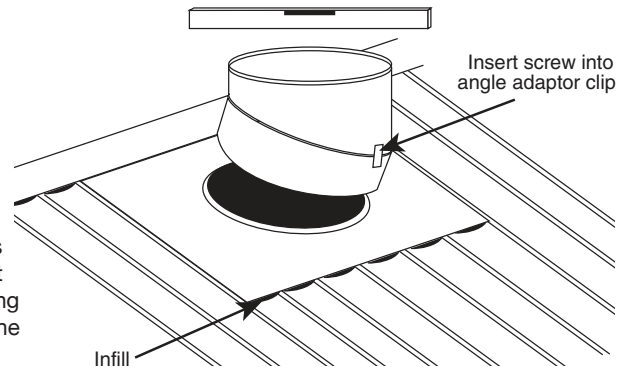

Step 3

When an variable pitch tube base is being used, sit the variable pitch tube on the flashing (wafered edge at top) and rotate the top and bottom halves until the top of the variable pitch tube is horizontal. It is recommended that a level be used. Secure the two halves of the variable pitch tube by inserting self tapping screws into the adaptor clips. Run a bead of silicone around the inside and outside and/or of the variable pitch tube seam.

DO NOT apply silicone to joint between flashing and Varipitch. lift the variable pitch section off the base plate slightly, this will act as a natural gutter to release any trapped water or condensation.

Step 4

Fix the variable pitch tube to the flashing with self tapping screws. (See Table 1 for the number of fasteners)

Step 5

Fit the turbine to the Variable Pitch Tube. Check that it is level and adjust by tilting if necessary. Fasten the turbine to the top of the Variable Pitch Tube with self tapping screws. (See Table 1 for the number of fasteners). **Run a bead of silicon between the 2 components.**

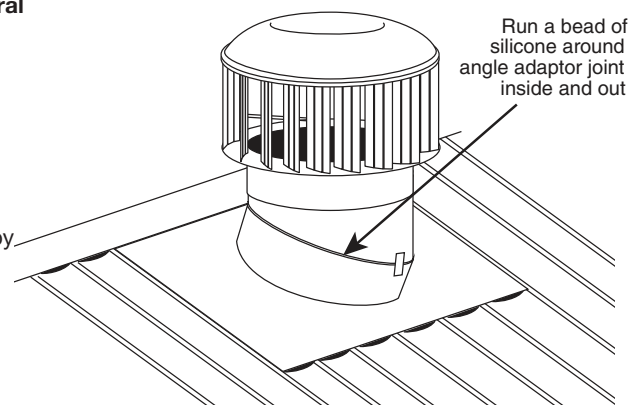

| Unit Size (mm) | Head to Angle Adaptor | Variable Pitch Tube to Flashing | Flashing to Roof (locate 4 close to variable pitch tube) |
|----------------|-----------------------|---------------------------------|---|
| 300 | 4 | 4 | 10 |
| 600 | 6 | 6 | 16 |
| 900 | 8 | 8 | 20 |

Either 10 gauge 16mm tek screw with neo or 4-3 blind rivets are recommended. When rivets are used apply silicone over the rivets to seal.

ALSYNITE HEAD OFFICE: Freephone 0800 257 964
Hamilton 07 850 5088

DISTRIBUTION CENTRES: Palmerston North 06 356 5384
Christchurch 03 348 3375
Invercargill 03 214 6002

DAMPER FOR WIND DRIVEN VENTILATORS

Remote Damper Installation

Overview

This Damper System is for use in Wind Driven Ventilators where the ventilation performance may need to be reduced at certain times.

The system offers the ability to stop at any position whilst opening or closing.

There is a gap of approximately 12mm around the circumference of the damper blade to allow air flow through the ventilator at all times.

Specifications

- Flap & Collar Material: 1mm Aluminium - 5005 H34
- Motor Specifications - 12DC - 50/60Hz - 2Nm
- Open Time: Approx. 15 seconds
- Close Time: Approx. 15 seconds
- Angle of Operation: 90 degrees
- Functions: Open, Close or Stop
- Remote Systems: Learning - one remote can operate any number of dampers
- Transformer: Input 110-240V 50/60Hz
- Output 12V DC

Installation Instructions

- **Follow steps 1 & 2 for ventilator installation overleaf.** Before securing the Base Flashing to the roof, insert and secure the Damper Ring under the Base Flashing. It will fit snugly into the up-stand and secure in place with rivets. At the highest point of the already cut hole, make a 100mm x 75mm cut-out to allow for the damper actuator to fit through. A power supply will be required at each position a ventilator is to be installed.
- **Continue from step 3**



PLEASE NOTE: *Alsynite can warrant that water does not infiltrate through the vanes in either still or windy conditions provided the vent is installed with allowance for make up air, not in wind shadows and is horizontal.*

Make-up air inlet area should be 3 times that of the exhaust (throat) area.

Where problems have been encountered on rare occasions – and amazingly in Australia and New Zealand only (less than 10 cases), water infiltration has been traced back to use of large vent capacities on buildings starved of sufficient make up air supply, wherein vents can suck water up the side of the throat, and once it reaches the top of the throat it will be sprayed out by the forces of the rotating top.

In this respect, it is easy at first hand to assume water is entering through the vanes. We are often not told that leakage occurs at night, when a building is typically tightly closed.

It is for this reason the use of remotely operated wall vents should be installed to work in conjunction with any systems with or without Dampers installed to the ventilators.

Particular caution should be applied with Gymnasium designs. These wall vents should remain partially open during winter months when the Vent dampers will be closed. This will allow for the make-up air to flow through the building at all times eliminating potential for water ingress.

On any roof with a low pitch, it is always advisable to ensure that a decent length throat is used on installation to maximise the distance between the Base and Vanes, this will help to avoid water rebound from the metal roof.