



Maximise your living space and modernise your outdoor living area with Custom Glaze™, a high quality polycarbonate roofing sheet that is engineered to withstand long-term outdoor UV exposure.

Selecting Custom Glaze™

Custom Glaze™ is suitable for a variety of existing and future structures where the rafters are designed to be placed specifically at 610mm centres. Custom Glaze™ is a very cost-effective polycarbonate roofing system providing a contemporary, stylish flat roof look without the need for expensive glazing bars.

Both the overlapping ribs are spaced at 610mm centres, allowing the overlapping rib to be positioned on the rafter effectively concealing the ribs when being viewed from below. Custom Glaze™ offers 99.9% UV protection and is extruded with an industry leading thickness of 2mm.

Custom Glaze™ is available in all standard and custom lengths* up to 7.2 metres.

STANDARD LENGTHS (m):

1.8, 2.1, 2.4, 2.7, 3.0, 3.6, 4.2, 4.8, 5.4, 6.0, 7.2

THICKNESS: 2mm

Profile

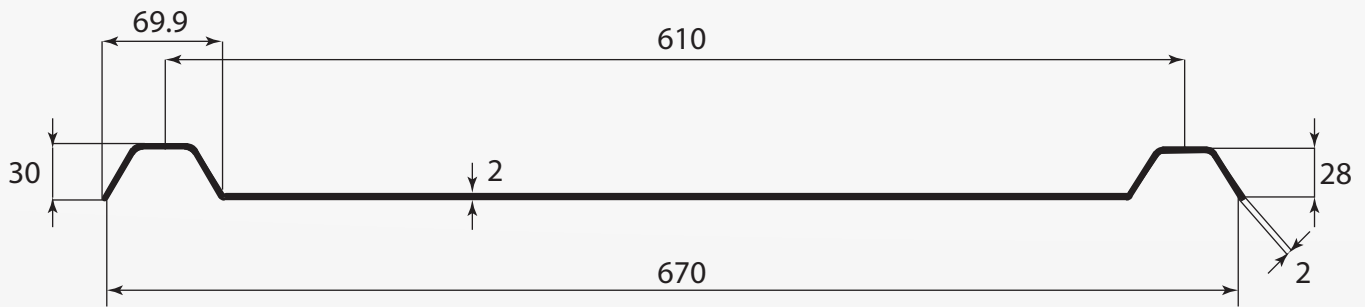

Colour

Custom Glaze™ is available in Clear, Diffused Opal, Bronze and Grey Tints.

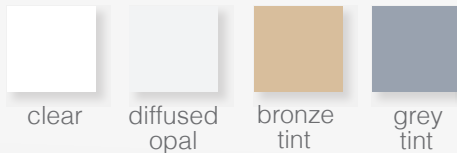

	clear	diffused opal	bronze tint	grey tint
Light Transmission %	93%	60%	23%	15%
Heat Reduction %	0%	44%	18%	34%

*Light Transmission in accordance with AS/NZS 4257.4 standard test method.
Heat Reduction in accordance with ISO 9050 Standard test method*

Warranty

Custom Glaze™ is supported by a comprehensive Lifetime (Loss of Light) Warranty and a 10 Year Weather Breakage Warranty.



WARMER

COOLER

Clear Diffused Opal Bronze Tint Grey Tint

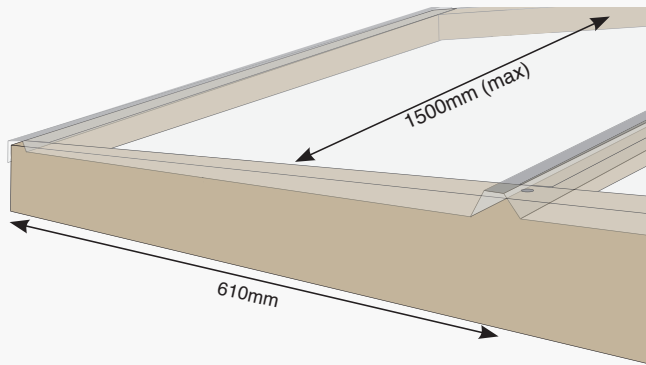

NOT TO SCALE

Barge Capping

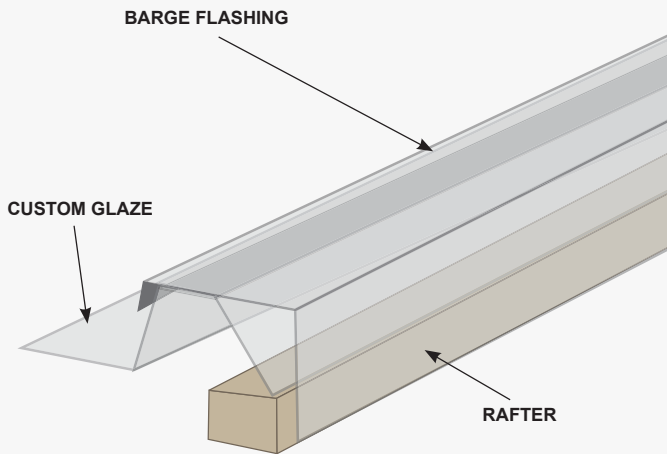

NOT TO SCALE

Barge Capping Profile

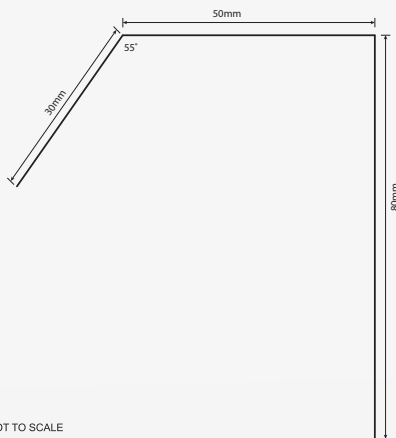

NOT TO SCALE

Metal Back Channel Flashing

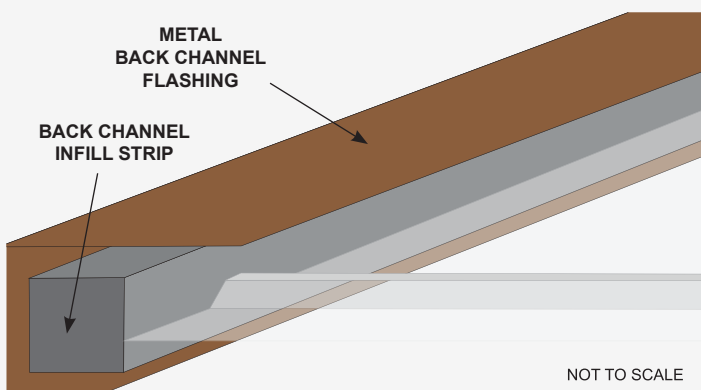

NOT TO SCALE

Installation Information

RECOMMENDED ROOF PITCH

The recommended minimum roof pitch for Custom Glaze™ is five degrees.

PURLIN SPACING

Custom Glaze™ is designed to be installed on purlins at a maximum of 1500mm centres.

For installations in snow prone areas, the purlin spans should be reduced to a maximum of 600mm centres.

NOISE STOP TAPE

Alsynite One Noise Stop Tape should be installed on purlins prior to fixing the sheet to the purlins.

FIXING CUSTOM GLAZE™ TO THE RAFTERS OR PURLINS.

Ensuring your Custom Glaze™ is presented in pristine condition, there is a protective film on both sides of the sheeting. Custom Glaze™ is to be fixed at every 400mm on all rafters, or fixed at 300mm for high wind zones. Fixing across the purlins is also recommended. To fasten Custom Glaze™, it is recommended that Custom Glaze™ Multipurpose Fasteners are used. They are specifically designed for fixing Custom Glaze™ securely to the purlins. Custom Glaze™ must be fixed on every crest of every purlin.

Custom Glaze™ has an overlapping rib and an underlapping rib, these are specifically designed so that the precise and effective cover is maintained across the structure.

Please ensure the overlapping side fits over the underlapping rib, refer to fixing instructions included in the pack for more information.

Handling, Storage & Cleaning

Store sheets on a flat surface in a well protected and shaded area, out of direct sunlight. Stacked sheets stored in the sun will cause heat build-up and possible distortion, even if covered. If damage occurs in this situation, the warranty is void.

Prevent moisture getting between stored sheets as this may cause whitening. Clean sheets regularly with warm, soapy water (mild detergent) and a soft sponge. Take care not to scratch the sheet. Hose down thoroughly.

Custom Glaze™ polycarbonate roofing is affected by methylated spirits, benzene, petrol, ketones, acetone, phenols, chlorinated and aromatic hydrocarbons, petroleum-based paints, abrasive cleaners and solvents.

*If you require a sheet length that is not standard, you will need to purchase the next standard length of sheet. e.g. if you require a length of 2.3m, you will need to purchase a 2.4m length sheet.

The measurements stated in this brochure are accurate, however the drawings are an artists impression and should not be relied upon when designing your structure.

Accessories

FASTENERS

6 x Alsynite One Multipurpose Fasteners
12g x 65mm with 32mm weatherlock washer per lineal metre

FLASHINGS *(to suit your roof design)*

Polycarbonate Barge Capping
Metal Back Channel Flashing

FOAM

Alsynite One Noise Stop Tape
Alsynite One Back Channel Infill Strip (optional)
Custom Glaze™ Eave Infill Strip

**CUSTOM
GLAZE™**

polycarbonate roofing to suit your lifestyle...

Custom Glaze™ is available from:

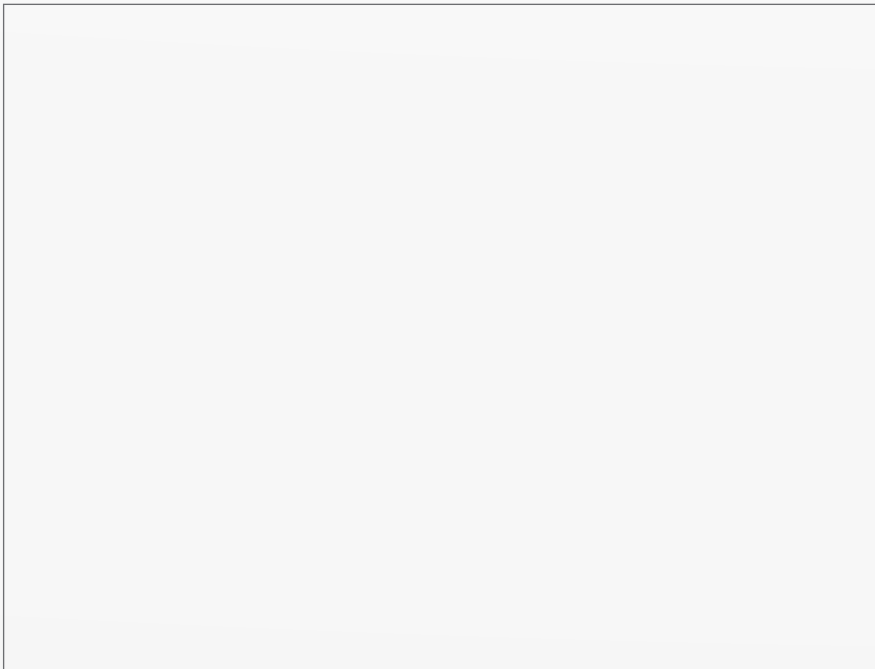

Custom Glaze™ is a Trademark of Impack International Pte Ltd.

Alsynite One NZ LTD

Head Office

7 De Leeuw Place
Te Rapa Park
Hamilton 3200
PO Box 10409
Te Rapa
Hamilton 3241
P 07 850 5088
F 07 850 5003

Distribution Centres:

Palmerston North

74 Malden Street
Roslyn
Palmerston North 4414
PO Box 4643
Manawatu Mail Centre
Palmerston North 4442
P 06 356 5384
F 06 356 5387

Christchurch

18 Nga Mahi Road
Sockburn
Christchurch 8042
PO Box 6083
Christchurch 8442
P 03 348 3375
F 03 348 3376

Invercargill

140 Mersey Street
Invercargill 9810